

# KENWOOD

## Rapid▷▷bake

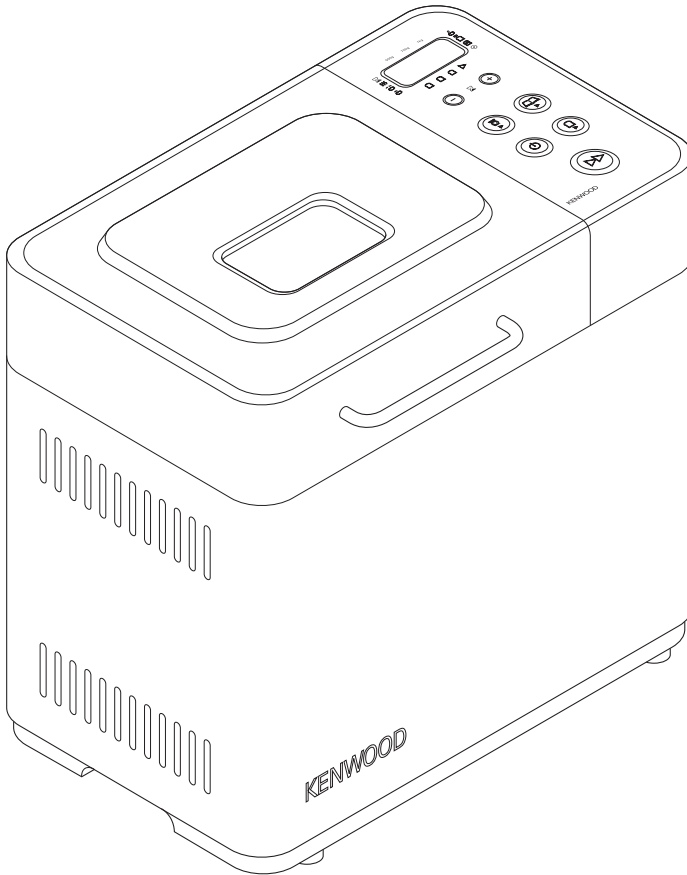

BM250

BM256



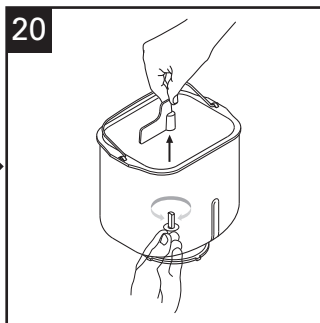
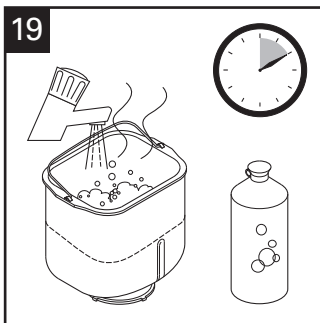
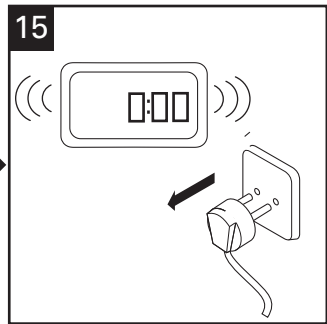
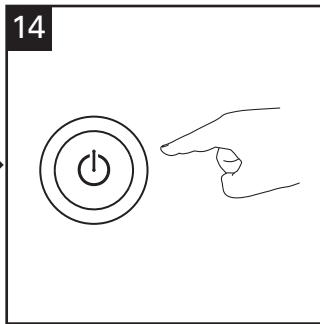
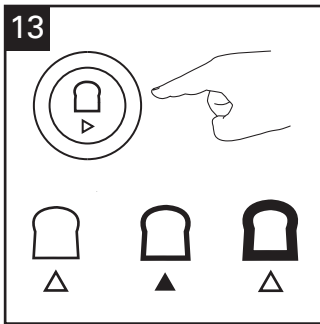
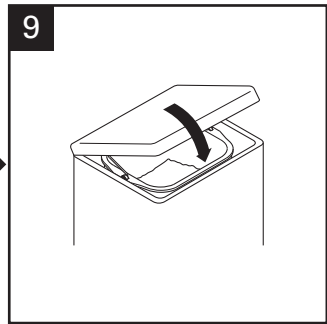
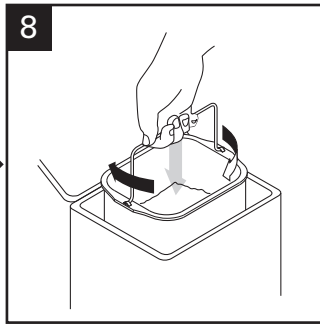
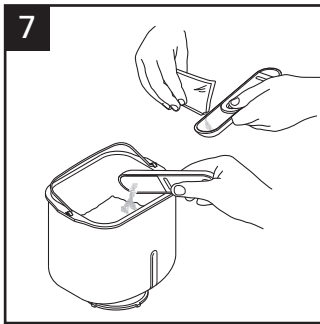
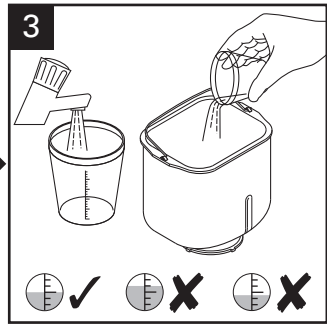
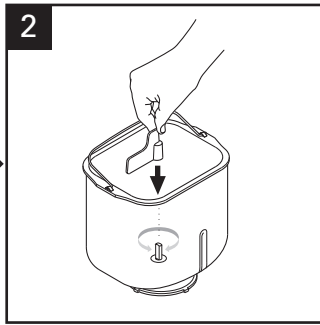
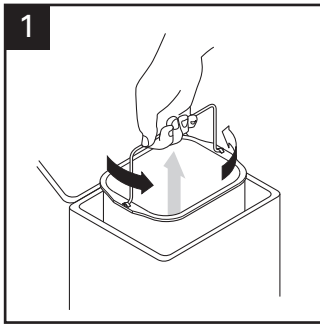

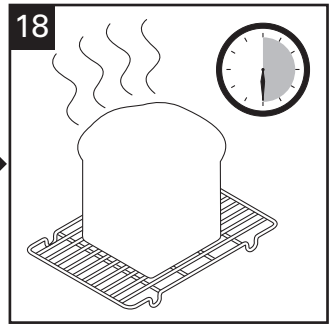
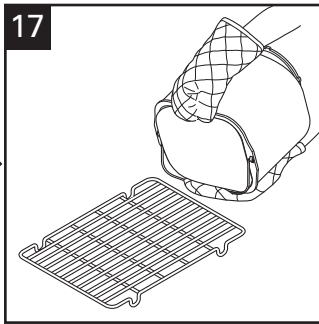
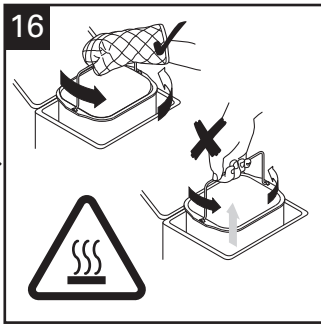
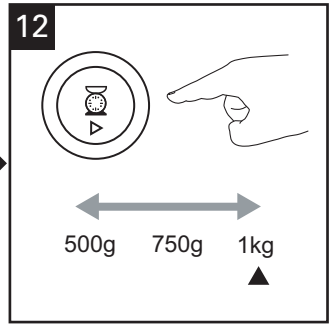
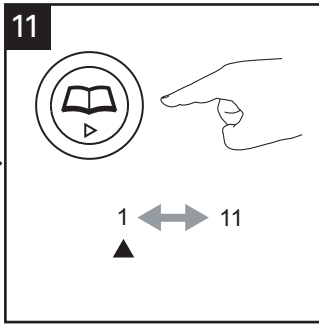
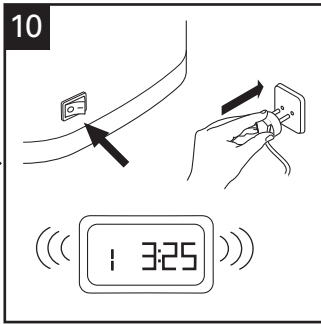
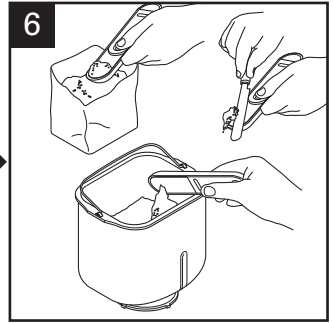
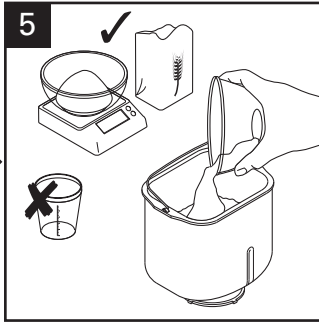
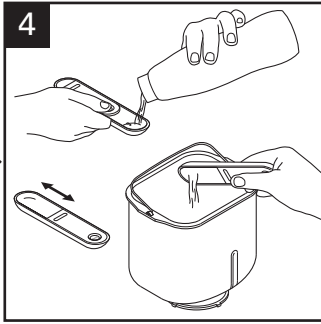

### **before using your Kenwood appliance**

- Read these instructions carefully and retain for future reference.
- Remove all packaging and any labels.

## safety

- Do not touch hot surfaces. Accessible surfaces are liable to get hot during use. Always use oven gloves to remove the hot bread pan.
- To prevent spillages inside the oven chamber, always remove the bread pan from the machine before adding the ingredients. Ingredients that splash onto the heating element can burn and cause smoke.
- Do not use this appliance if there is any visible sign of damage to the supply cord or if it has been accidentally dropped.
- Do not immerse this appliance, the supply cord or the plug in water or any other liquid.
- Always unplug this appliance after use, before fitting or removing parts or before cleaning.
- Do not let the electrical supply cord hang over the edge of a work surface or allow it to touch hot surfaces such as a gas or electric hob.
- This appliance should only be used on a flat heat resistant surface.
- Do not place your hand inside the oven chamber after the bread pan has been removed as it will be very hot.
- Do not touch moving parts within the Bread Maker.
- Do not exceed the maximum flour and raising agent quantities specified in the recipes supplied.
- Do not place the Bread Maker in direct sun light, near hot appliances or in a draught. All these things can affect the internal temperature of the oven, which could spoil the results.
- Do not use this appliance outdoors.
- Do not operate the Bread Maker when it is empty as this could cause it serious damage.
- Do not use the oven chamber for any type of storage.
- Do not cover the steam vents in the lid and ensure there is adequate ventilation around the bread maker during operation.
- This appliance is not intended to be operated by means of an external timer or separate remote-control system.
- This appliance is not intended for use by persons (including children) with reduced physical, sensory or mental capabilities, or lack of experience and knowledge, unless they have been given supervision or

instruction concerning use of the appliance by a person responsible for their safety.

- Children should be supervised to ensure that they do not play with the appliance.
- Only use the appliance for its intended domestic use. Kenwood will not accept any liability if the appliance is subject to improper use, or failure to comply with these instructions.

### **before plugging in**

- Make sure your electricity supply is the same as the one shown on the underside of your Bread Maker.
- **IMPORTANT: UK only** – The wires in the cord are coloured as follows:

**Green & Yellow = Earth**

**Blue = Neutral**

**Brown = Live**

- This appliance conforms to EC directive 2004/108/EC on Electromagnetic Compatibility and EC regulation no. 1935/2004 of 27/10/2004 on materials intended for contact with food.

### **before using your bread maker for the first time**

- Wash all parts (see care and cleaning).

## key

- ① lid handle
- ② viewing window
- ③ heating element
- ④ bread pan handle
- ⑤ kneader
- ⑥ drive shaft
- ⑦ drive coupling
- ⑧ on/off switch
- ⑨ measuring cup
- ⑩ dual measuring spoon 1tsp & 1tbsp
- ⑪ control panel
- ⑫ display window
- ⑬ timer indicator
- ⑭ program status indicator
- ⑮ crust colour indicators (light, medium, dark, rapid)
- ⑯ delay timer buttons
- ⑰ loaf size button
- ⑱ start/stop button
- ⑲ rapid bake button
- ⑳ crust colour button
- ㉑ menu button
- ㉒ loaf size indicators

## how to measure ingredients (refer to illustrations 3 to 7)

It is extremely important to use the exact measure of ingredients for best results.

- Always measure liquid ingredients in the see-through measuring cup with graduated markings provided. Liquid should just reach marking on cup at eye level, not above or below (see 3).
- Always use liquids at room temperature, 20°C/68°F, unless making bread using the rapid 1 hour cycle. Follow the instructions given in the recipe section.
- Always use the measuring spoon provided to measure smaller quantities of dry and liquid ingredients. Use the slider to select between the following measure - ½ tsp, 1 tsp, ½ tbsp or 1 tbsp. Fill to the top and level off the spoon (see 6 & 7).

## on/off switch

Your Kenwood breadmaker is fitted with an ON/OFF switch and will not operate until the “on” switch is pressed.

- Plug in and press the ON/OFF switch (8) situated at the back of the breadmaker - the unit will beep and 3:25 will appear in the display window.
- Always switch off and unplug your breadmaker after use.

## program status indicator (14)

The program status indicator is situated in the display window and the indicator arrow will point to the stage of the cycle the breadmaker has reached as follows: -

Pre-heat  – The pre-heat feature only operates at the start of the wholewheat setting (30 minutes) and wholemeal rapid (5 minutes) to warm the ingredients before the first kneading stage begins. There is no kneader action during this period.

Knead  – The dough is either in the first or 2nd kneading stage or being knocked back between the rising cycles. During the last 10minutes of the 2nd Kneading cycle on setting (1), (3), (4) an alert will sound to tell you to add any additional ingredients manually.

Rest  – dough is being rested between the kneading cycles.

Rise  – the dough is in either the 1st, 2nd or 3rd rising cycle.

Bake  – The loaf is in the final baking cycle.

Keep Warm  – The bread maker automatically goes into the Keep warm mode at the end of the baking cycle. It will stay on the keep warm mode for up to 1hour or until the machine is turned off, which ever is soonest. **Please note: the heating element will switch on and off and will glow intermittently during the keep warm cycle.**

End  – end of program.

## using your Bread Maker (refer to illustration panel)

- 1 Remove the bread pan by holding the handle and turning the pan to the back of the baking chamber.
- 2 Fit the kneader.
- 3 Pour the water into the bread pan.
- 4 Add the rest of the ingredients to the pan in the order listed in the recipes.
- ▲ Ensure that all the ingredients are weighed accurately as incorrect measures will produce poor results.
- ▼
- 7 Insert the bread pan into the oven chamber by positioning the bread pan at an angle towards the back of the unit. Then lock the pan by turning it towards the front.
- 8 Lower the handle and close the lid.
- 9 Plug in and switch on - the unit will beep and default to setting 1 (3:25).
- 10 Press the MENU button (21) until the required program is selected. The breadmaker will default to 1Kg & medium crust colour. Note: If using the “RAPID BAKE” (19), just press the button and the program will start automatically.
- 12 Select the loaf size by pressing the LOAF SIZE button (17) until the indicator moves to the required loaf size.
- 13 Select the crust colour by pressing the CRUST button (20) until the indicator moves to the required crust colour (light, medium or dark).
- 14 Press the START button (18). To stop or cancel the program press the START/STOP button for 2 – 3 seconds.
- 15 At the end of the baking cycle unplug the breadmaker
- 16 Remove the bread pan by holding the handle and turning the pan to the back of the baking chamber. **Always use oven gloves as the pan handle will be hot.**
- 17 Then turn out onto a wire rack to cool.

- 18 Leave the bread to cool for at least 30 minutes before slicing, to allow the steam to escape. The bread will be difficult to slice if hot.
- 19 Clean the bread pan and kneader immediately after use (see care and cleaning).

## delay timer

The Delay timer allows you to delay the bread making process up to 15 hours. The delayed start cannot be used with the “RAPID BAKE” program and is not recommended for use with either the dough, jam or gluten free settings.

**IMPORTANT:** When using this delayed start function you must not use perishable ingredients – things that ‘go off’ easily at room temperature or above, such as milk, egg, cheese and yoghurt etc.

To use the DELAY TIMER simply place the ingredients in the bread pan and lock the pan into the bread maker. Then:

- Press the MENU pad  to choose the required program – the program cycle time is displayed.
- Select the crust colour and size required.
- Then set the delay timer.
- Press the (+) TIMER pad and keep pressing until the total time required is displayed. If you go past the required time press the (-) TIMER pad to go back. The timer pad when pressed, moves in 10 minute increments. You do not need to work out the difference between the program time selected and the total hours required as the bread maker will automatically include the setting cycle time.

*Example:* Finished loaf required at 7am. If the breadmaker is set up with the required recipe ingredients at 10pm the evening before, total time to be set on the delayed timer is 9 hours.

- Press the MENU pad to choose your program e.g. 1 and use the (+) timer pad to scroll the time in 10 minute increments to display ‘9:05’. If you go past ‘9:05’, simply press the (-) timer pad until you return to ‘9:05’.



3:25

- Press the start pad and the display colon (:) will flash. The timer will start to count down.
- If you make a mistake or wish to change the time set, press the START/STOP pad until it beeps. You can then reset the time.



09:05



09:05

## power interruption protection

Your Bread Maker has an 8 minute power interruption protection in case the unit is accidentally unplugged during operation. The unit will continue the program if plugged back in straight away.

## care and cleaning

**IMPORTANT:** unplug the Bread Maker and allow to cool before cleaning.

- Do not immerse either the Bread Maker body or the outside base of the bread pan in water.
- Do not use a dishwasher to clean bread pan. Dishwashing can damage the non-stick properties of the bread pan allowing bread to stick during baking.
- Do not use abrasive scouring pads or metal implements.
- Clean the bread pan and the kneader **immediately** after each use by partially filling the pan with warm soapy water. Leave to soak for 5 to 10 minutes. To remove the kneader, turn clockwise and lift off. Finish cleaning with a soft cloth, rinse and dry.
- If the kneader cannot be removed after 10 minutes, hold the shaft from underneath the pan and twist back and forth until the kneader is released.
- Use a soft damp cloth to clean the outside and inside surfaces of the Bread Maker if necessary.
- The lid can be lifted off for cleaning.

## service and customer care

- If the cord is damaged it must, for safety reasons, be replaced by KENWOOD or an authorised KENWOOD repairer.

If you need help with:

- using your machine or
  - servicing or repairs (in or out of guarantee)
- ☎ call Kenwood customer care on **023 9239 2333**.

**Have your model number ready** - it is located on the base of your Bread Maker.

### ● **spares and attachments**

☎ call 0870 2413653.

### **other countries**

- Contact the shop where you bought your Bread Maker.
- Designed and engineered by Kenwood in the UK.
- Made in China.



## **IMPORTANT INFORMATION FOR CORRECT DISPOSAL OF THE PRODUCT IN ACCORDANCE WITH EC DIRECTIVE 2002/96/EC.**

At the end of its working life, the product must not be disposed of as urban waste.

It must be taken to a special local authority differentiated waste collection centre or to a dealer providing this service. Disposing of a household appliance separately avoids possible negative consequences for the environment and health deriving from inappropriate disposal and enables the constituent materials to be recovered to obtain significant savings in energy and resources. As a reminder of the need to dispose of household appliances separately, the product is marked with a crossed-out wheeled dustbin.

## **UK only Guarantee**

If your Bread Maker goes wrong within one year from the date you bought it, we will repair it (or replace it if necessary) free of charge provided:

- You have not misused, neglected or damaged it
- It has not been modified (unless by Kenwood)
- It is not second hand
- It has not been used commercially
- You have not fitted a plug incorrectly
- You supply your receipt to show when you bought it

This guarantee does not affect your statutory rights.

## bread/dough program chart

program		Total Program Time				Alert For Adding Ingredients			Keep Warm
		500g	750g	1Kg	1Kg	500g	750g	1Kg	
<b>1 basic</b>	White or Brown Bread Flour recipes	3:13	3:18	3:25		2:51	2:56	3:03	60
<b>2 french</b>	Produces a crisper crust and suited to loaves low in fat and sugar	3:30	3:32	3:35		-	-	-	60
<b>3 wholewheat</b>	Rapid Loaves *	2:30	2:32	2:35		-	-	-	
	Wholewheat or wholemeal flour recipes: 30 minute preheat	3:43	3:45	3:48		2:56	2:58	3:01	60
<b>4 sweet</b>	Rapid Loaves: 5 minute preheat *	2:28	2:30	2:33		-	-	-	60
<b>5 gluten free</b>	High sugar bread recipes	3:17	3:22	3:27		2:55	3:00	3:05	60
	For use with gluten free flours and gluten free bread mixes. Max 500g flour wt		2:24			-	-	-	60
<b>6 packet mix</b>	For ready prepared bread mixes Max 500g mix		2:24			-	-	-	60
<b>7 cake</b>	Non-yeast batter breads and cakes		1:43			-	-	-	-
<b>8 dough</b>	Dough for hand shaping and baking in your own oven.		1:30			-	-	-	-
<b>9 pasta dough</b>	Pasta dough recipes		0:14			-	-	-	-
<b>10 jam</b>	For making jams		1:05			-	-	-	-
<b>11 bake</b>	Bake only feature. Can also be used to rewarm or crisp loaves already baked and cooled.		1:00			-	-	-	60
<b>rapid bake button</b>	Produces loaves of bread in under 1 hour. Loaves require warm water, extra yeast and less salt.		0:58			-	-	-	60

★ To select the rapid loaf program press the crust colour pad until the indicator points to (▷).

★★ An alert will sound before the end of the 2nd kneading cycle to add ingredients if the recipe recommends doing so.

★★★ The Bread maker will automatically go in to the keep warm mode at the end of the baking cycle. It will stay in the keep warm mode for up to 1 hour or until the machine is turned off, which ever is sooner.

## Recipes (add the ingredients to the pan in the order listed in the recipes)

### Basic White Bread

#### Program 1

<b>Ingredients</b>	<b>500g</b>	<b>750g</b>	<b>1Kg</b>
Water	245ml	290ml	380ml
Vegetable oil	1tbsp	1½tbsp	1½tbsp
Unbleached white bread flour	350g	450g	600g
Skimmed milk powder	1tbsp	4tsp	2tbsp
Salt	1tsp	1½tsp	1½tsp
Sugar	2tsp	1tbsp	4tsp
Easy blend dried yeast	1tsp	1½tsp	1½tsp

tsp = 5 ml teaspoon

tbsp = 15ml tablespoon

### Brioche Bread

#### Program 4

<b>Ingredients</b>	<b>500g</b>	<b>750g</b>	<b>1Kg</b>
Milk	130ml	220ml	260ml
Eggs	1	2	2
Butter, melted	80g	140g	180g
Unbleached white bread flour	350g	500g	600g
Salt	1tsp	1tsp	1½tsp
Sugar	30g	60g	80g
Easy blend dried yeast	1½tsp	2tsp	2½tsp

### Wholemeal Seeded Bread

#### Program 3

<b>Ingredients</b>	<b>750g</b>	<b>1Kg</b>
Water	300mls	380mls
Vegetable Oil	1tbsp	1½tbsp
Wholemeal bread flour	400g	500g
Unbleached white bread flour	50g	100g
Skimmed milk powder	4tsp	2tbsp
Salt	1tsp	1½tsp
Sugar	2tsp	1tbsp
Easy blend dried yeast	1tsp	1tsp
Pumpkin Seeds	3tsp	3tsp
Sunflower seeds	3tsp	3tsp
Poppy seeds	2tsp	3tsp
Lightly toasted sesame seeds	2tsp	3tsp

1. Add the seeds when the machine makes an audible sound during the 2nd kneading cycle.

## Rapid White Bread

## Rapid Bake Button

<b>Ingredients</b>	<b>1Kg</b>
<i>Milk, lukewarm (32-35°C)</i>	350ml
<i>Egg</i>	50ml
<i>Vegetable oil</i>	1tbsp
<i>Unbleached white bread flour</i>	600g
<i>Skimmed milk powder</i>	2tbsp
<i>Salt</i>	1tsp
<i>Sugar</i>	4tsp
<i>Easy blend dried yeast</i>	4tsp

1 Press the RAPID BAKE button and the program will start automatically.

## Bread rolls

## Program 8

<b>Ingredients</b>	<b>1Kg</b>
<i>Water</i>	240ml
<i>Egg</i>	1
<i>Unbleached white bread flour</i>	450g
<i>Salt</i>	1tsp
<i>Sugar</i>	2tsp
<i>Butter</i>	25g
<i>Easy blend dried yeast</i>	1½tsp
<b>For the topping:</b>	
<i>Egg yolk beaten with 15ml (1tbsp) water</i>	1
<i>Sesame seeds and poppy seeds, for sprinkling, optional</i>	

- 1 At the end of the cycle, turn the dough out onto a lightly floured surface. Gently knock back the dough and divide into 12 equal pieces and hand shape.
- 2 After shaping, leave the dough for a final proving then bake in your conventional oven.

## ingredients

The major ingredient in bread making is flour, so selecting the right one is the key to a successful loaf.

### **wheat flours**

Wheat flours make the best loaves. Wheat consists of an outer husk, often referred to as bran, and an inner kernel, which contains the wheat germ and endosperm. It is the protein within the endosperm which, when mixed with water, forms gluten. Gluten stretches like elastic and the gases given off by the yeast during fermentation are trapped, making the dough rise.

### **white flours**

These flours have the outer bran and wheat germ removed, leaving the endosperm which is milled into a white flour. It is essential to use strong white flour or white bread flour, because this has a higher protein level, necessary for gluten development. Do not use plain white flour or self-raising flour for making yeast risen breads in your bread maker, as inferior loaves will be produced. There are several brands of white bread flour available, use a good quality one, preferably unbleached, for the best results.

### **wholemeal flours**

Wholemeal flours include the bran and wheat germ, which gives the flour a nutty flavour and produces a coarser textured bread. Again strong wholemeal or wholemeal bread flour must be used. Loaves made with 100% wholemeal flour will be more dense than white loaves. The bran present in the flour inhibits the release of gluten, so wholemeal doughs rise more slowly. Use the special wholewheat programs to allow time for the bread to rise. For a lighter loaf, replace part of the wholemeal flour with white bread flour. You can make a quick wholemeal loaf using the rapid whole wheat setting.

### **strong brown flour**

This can be used in combination with white flour, or on its own. It contains about 80-90% of the wheat kernel and so it produces a lighter loaf, which is still full of flavour. Try using this flour on the basic white cycle, replacing 50% of the strong white flour with strong brown flour. You may need to add a little extra liquid.

### **granary bread flour**

A combination of white, wholemeal and rye flours mixed with malted whole wheat grains, which adds both texture and flavour. Use on its own or in combination with strong white flour.

### **non-wheat flours**

Other flours such as rye can be used with white and wholemeal bread flours to make traditional breads like pumpernickel or rye bread. Adding even a small amount adds a distinctive tang. Do not use on its own, as it will produce a sticky dough, which will produce a dense heavy loaf. Other grains such as millet, barley, buckwheat, cornmeal and oatmeal are low in protein and therefore do not develop sufficient gluten to produce a traditional loaf.

These flours can be used successfully in small quantities. Try replacing 10-20% of white bread flour with any of these alternatives.

### **salt**

A small quantity of salt is essential in bread making for dough development and flavour. Use fine table salt or sea salt, not coarsely ground salt which is best kept for sprinkling on top of hand-shaped rolls, to give a crunchy texture. Low-salt substitutes are best avoided as most do not contain sodium.

- Salt strengthens the gluten structure and makes the dough more elastic.
- Salt inhibits yeast growth to prevent over-rising and stops the dough collapsing.
- Too much salt will prevent the dough rising sufficiently.

### **sweeteners**

Use white or brown sugars, honey, malt extract, golden syrup, maple syrup, molasses or treacle.

- Sugar and liquid sweeteners contribute to the colour of bread, helping to add a golden finish to the crust.
- Sugar attracts moisture, so improving the keeping qualities.
- Sugar provides food for the yeast, although not essential, as modern types of dried yeast are able to feed on the natural sugars and starches found in the flour, it will make the dough more active.
- Sweet breads have a moderate level of sugar with the fruit, glaze or icing adding extra sweetness. Use the sweet bread cycle for these breads.
- If substituting a liquid sweetener for sugar then the total liquid content of the recipe will need to be reduced slightly.

## **fats and oils**

A small amount of fat or oil is often added to bread to give a softer crumb. It also helps to extend the freshness of the loaf. Use butter, margarine or even lard in small quantities up to 25 g (1 oz) or 22ml (1/2 tbsp.) vegetable oil. Where a recipe uses larger amounts so the flavour is more noticeable, butter will provide the best result.

- Olive oil or sunflower oil can be used instead of butter, adjust the liquid content for amounts over 15ml (3 tsp) accordingly. Sunflower oil is a good alternative if you are concerned about the cholesterol level.
- Do not use low fat spreads as they contain up to 40% water so do not have the same properties as butter.

## **liquid**

Some form of liquid is essential; usually water or milk is used. Water produces a crisper crust than milk. Water is often combined with skimmed milk powder. This is essential if using the time delay as fresh milk will deteriorate. For most programs water straight from the tap is fine, however on the rapid one-hour cycle it needs to be lukewarm.

- On very cold days measure the water and leave to stand at room temperature for 30 minutes before use. If using milk straight from the fridge do likewise.
- Buttermilk, yoghurt, soured cream and soft cheeses such as ricotta, cottage and fromage fraise can all be used as part of the liquid content to produce a more moist, tender crumb. Buttermilk adds a pleasant, slightly sour note, not unlike that found in country style breads and sour doughs.
- Eggs may be added to enrich the dough, improve the colour of the bread and help to add structure and stability to the gluten during rising. If using eggs reduce the liquid content accordingly. Place the egg in a measuring cup and top up with liquid to the correct level for the recipe.

## **yeast**

Yeast is available both fresh and dried. All the recipes in this book have been tested using easy blend, fast action dried yeast which does not require dissolving in water first. It is placed in a well in the flour where it is kept dry and separate from the liquid until mixing commences.

- For best results use dried yeast. The use of fresh yeast is not recommended as it tends to give more variable results than dried yeast. Do not use fresh yeast with the delay timer.

If you wish to use fresh yeast note the following:

6g fresh yeast = 1tsp dried yeast

Mix the fresh yeast with 1tsp sugar and 2tbsp of the water (warm). Leave for 5 minutes until frothy.

Then add to the rest of the ingredients in the pan.

To get the best results the yeast quantity may need to be adjusted.

- Use the amounts stated in the recipes; too much could cause the bread to over-rise and spill over the top of the bread pan.
- Once a sachet of yeast is opened, it should be used within 48 hours, unless stated otherwise by the manufacturer. Re-seal after use. Resealed opened sachets can be stored in the freezer until required.
- Use dried yeast before its use by date, as the potency gradually deteriorates with time.
- You may find dried yeast, which has been manufactured especially for use in bread machines. This will also produce good results, though you may need to adjust the quantities recommended.

## adapting your own recipes

After you have baked some of the recipes, supplied in this booklet, you may wish to adapt a few of your own favourites, which previously have been mixed and kneaded by hand. Start by selecting one of the recipes in this booklet, which is similar to your recipe, and use it as a guide.

Read through the following guidelines to help you, and be prepared to make adjustments as you go along.

- Make sure you use the correct quantities for the bread maker. Do not exceed the recommended maximum. If necessary, reduce the recipe to match the flour and liquid quantities in the breadmaker recipes.
- Always add the liquid to the bread pan first. Separate the yeast from the liquid by adding after the flour.
- Replace fresh yeast with easy blend dried yeast. Note: 6g fresh yeast = 1tsp (5ml) dried yeast.
- Use skimmed milk powder and water instead of fresh milk, if using the timer delay setting.
- If your conventional recipe uses egg, add the egg as part of the total liquid measurement.
- Keep the yeast separate from the other ingredients in the pan until mixing commences.
- Check the consistency of the dough during the first few minutes of mixing. Bread machines require a slightly softer dough, so you may need to add extra liquid. The dough should be wet enough to gradually relax back.

## removing, slicing and storing bread

- For best results, once your loaf is baked, remove it from the machine and turn out of the bread pan immediately, although your bread maker will keep it warm for up to 1 hour if you are not around.
- Remove the bread pan from the machine using oven gloves, even if it is during the keep warm cycle. Turn the pan upside-down and shake several times to release the cooked bread. If the bread is difficult to remove, try gently knocking the corner of the bread pan on a wooden board, or rotate the base of the shaft underneath the bread pan.
- The kneader should remain inside the bread pan when the bread is released, however occasionally it may remain inside the loaf of bread. If so, remove it before slicing the bread, using a heat resistant plastic utensil to prise it out. Do not use a metal implement as this may scratch the non-stick coating on the kneader.
- Leave the bread to cool for at least 30 minutes on a wire rack, to allow the steam to escape. The bread will be difficult to slice if cut hot.

### storing

Home-made bread does not contain any preservatives so should be eaten within 2-3 days of baking. If not eating immediately, wrap in foil or place in a plastic bag and seal.

- Crispy French-style bread will soften on storage, so is best left uncovered until sliced.
- If you wish to keep your bread for a few days, store in the freezer. Slice the bread before freezing, for easy removal of the amount required.

## general hints and tips

The results of your bread making are dependent on a number of different factors, such as the quality of ingredients, careful measuring, temperature and humidity. To help ensure successful results, there are a few hints and tips worth noting.

The bread machine is not a sealed unit and will be affected by temperature. If it is a very hot day or the machine is used in a hot kitchen, then the bread is likely to rise more, than if it is cold. The optimum room temperature is between 20°C /68°F and 24°C/75°F.

- On very cold days let the water from the tap stand at room temperature for 30 minutes before use. Likewise with ingredients from the fridge.
  - Use all ingredients at room temperature unless stated otherwise in the recipe eg. for the rapid 1 hour cycle you will need to warm the liquid.
  - Add ingredients to the bread pan in the order suggested in the recipe. Keep the yeast dry and separate from any other liquids added to the pan, until mixing commences.
  - Accurate measuring is probably the most crucial factor for a successful loaf. Most problems are due to inaccurate measuring or omitting an ingredient. Follow either metric or imperial measurements; they are not interchangeable. Use the measuring cup and spoon provided.
  - Always use fresh ingredients, within their use by date. Perishable ingredients such as milk, cheese, vegetables and fresh fruits may deteriorate, especially in warm conditions. These should only be used in breads, which are made immediately.
  - Do not add too much fat as it forms a barrier between the yeast and flour, slowing down the action of the yeast, which could result in a heavy compact loaf.
  - Cut butter and other fats into small pieces before adding to the bread pan.
  - Replace part of the water with fruit juices such as orange, apple or pineapple when making fruit flavoured breads.
  - Vegetable cooking juices can be added as part of the liquid. Water from cooking potatoes contains starch, which is an additional source of food for the yeast, and helps to produce a well-risen, softer, longer lasting loaf.
- Vegetables such as grated carrot, courgette or cooked mashed potato can be added for flavour. You will need to reduce the liquid content of the recipe as these foods contain water. Start with less water and check the dough as it begins to mix and adjust if it is necessary.
  - Do not exceed the quantities given in recipes as you may damage your bread machine.
  - If the bread does not rise well try replacing the tap water with bottled water or boiled and cooled water. If your tap water is heavily chlorinated and fluorinated it may affect the bread rising. Hard water can also have this effect.
  - It is worth checking the dough after about 5 minutes of continuous kneading. Keep a flexible rubber spatula next to the machine, so you can scrape down the sides of the pan if some of the ingredients stick to the corners. Do not place near the kneader, or impede its movement. Also check the dough to see if it is the correct consistency. If the dough is crumbly or the machine seems to be labouring, add a little extra water. If the dough is sticking to the sides of the pan and doesn't form a ball, add a little extra flour.
  - Do not open the lid during the proving or baking cycle as this may cause the bread to collapse.

## troubleshooting guide

Following are some typical problems that can occur when making bread in your bread maker. Please review the problems, their possible cause and the corrective action that should be taken to ensure successful bread making.

<b>PROBLEM</b>	<b>POSSIBLE CAUSE</b>	<b>SOLUTION</b>
<b>LOAF SIZE AND SHAPE</b>		
1. Bread does not rise enough	<ul style="list-style-type: none"> <li>• Wholemeal breads will be lower than white breads due to less gluten forming protein in whole wheat flour.</li> <li>• Not enough liquid.</li> <li>• Sugar omitted or not enough added.</li> <li>• Wrong type of flour used.</li> <li>• Wrong type of yeast used.</li> <li>• Not enough yeast added or too old.</li> <li>• Rapid bread cycle chosen.</li> <li>• Yeast and sugar came into contact with each other before kneading cycle.</li> </ul>	<ul style="list-style-type: none"> <li>• Normal situation, no solution.</li> <li>• Increase liquid by 15ml/3tsp.</li> <li>• Assemble ingredients as listed in recipe.</li> <li>• You may have used plain white flour instead of strong bread flour which has a higher gluten content.</li> <li>• Do not use all-purpose flour.</li> <li>• For best results use only fast action "easy blend" yeast.</li> <li>• Measure amount recommended and check expiry date on package.</li> <li>• This cycle produces shorter loaves. This is normal.</li> <li>• Make sure they remain separate when added to the bread pan.</li> </ul>
2. Flat loaves, no rising.	<ul style="list-style-type: none"> <li>• Yeast omitted.</li> <li>• Yeast too old.</li> <li>• Liquid too hot.</li> <li>• Too much salt added.</li> <li>• If using timer, yeast got wet before bread making process started.</li> </ul>	<ul style="list-style-type: none"> <li>• Assemble ingredients as listed in recipe.</li> <li>• Check expiry date.</li> <li>• Use liquid at correct temperature for bread setting being used.</li> <li>• Use amount recommended.</li> <li>• Place dry ingredients into corners of pan and make slight well in centre of dry ingredients for yeast to protect it from liquids.</li> </ul>
3. Top inflated - mushroom-like in appearance.	<ul style="list-style-type: none"> <li>• Too much yeast.</li> <li>• Too much sugar.</li> <li>• Too much flour.</li> <li>• Not enough salt.</li> <li>• Warm, humid weather.</li> </ul>	<ul style="list-style-type: none"> <li>• Reduce yeast by 1/4tsp.</li> <li>• Reduce sugar by 1tsp.</li> <li>• Reduce flour by 6 to 9tsp.</li> <li>• Use amount of salt recommended in recipe.</li> <li>• Reduce liquid by 15ml/3 tsp and yeast by 1/4 tsp.</li> </ul>
4. Top and sides cave in.	<ul style="list-style-type: none"> <li>• Too much liquid.</li> <li>• Too much yeast.</li> <li>• High humidity and warm weather may have caused the dough to rise too fast.</li> </ul>	<ul style="list-style-type: none"> <li>• Reduce liquid by 15ml/3tsp next time or add a little extra flour.</li> <li>• Use amount recommended in recipe or try a quicker cycle next time.</li> <li>• Chill the water or add milk straight from the fridge</li> </ul>
5. Gnarly, knotted top - not smooth.	<ul style="list-style-type: none"> <li>• Not enough liquid.</li> <li>• Too much flour.</li> <li>• Tops of loaves may not all be perfectly shaped, however, this does not affect wonderful flavour of bread.</li> </ul>	<ul style="list-style-type: none"> <li>• Increase liquid by 15ml/3tsp.</li> <li>• Measure flour accurately.</li> <li>• Make sure dough is made under the best possible conditions.</li> </ul>

## troubleshooting guide *(continued)*

<b>PROBLEM</b>	<b>POSSIBLE CAUSE</b>	<b>SOLUTION</b>
<b>LOAF SIZE AND SHAPE</b>		
6. Collapsed while baking.	<ul style="list-style-type: none"> <li>Machine was placed in a draught or may have been knocked or jolted during rising.</li> <li>Exceeding capacity of bread pan.</li> <li>Not enough salt used or omitted. (salt helps prevent the dough over proving)</li> <li>Too much yeast.</li> <li>Warm, humid weather.</li> </ul>	<ul style="list-style-type: none"> <li>Reposition bread maker.</li> <li>Do not use more ingredients than recommended for large loaf (max. 1Kg).</li> <li>Use amount of salt recommended in recipe.</li> <li>Measure yeast accurately.</li> <li>Reduce liquid by 15ml/3tsp and reduce yeast by 1/4tsp.</li> </ul>
7. Loaves uneven shorter on one end.	<ul style="list-style-type: none"> <li>Dough too dry and not allowed to rise evenly in pan.</li> </ul>	<ul style="list-style-type: none"> <li>Increase liquid by 15ml/3 tsp.</li> </ul>
<b>BREAD TEXTURE</b>		
8. Heavy dense texture.	<ul style="list-style-type: none"> <li>Too much flour.</li> <li>Not enough yeast.</li> <li>Not enough sugar.</li> </ul>	<ul style="list-style-type: none"> <li>Measure accurately.</li> <li>Measure right amount of recommended yeast.</li> <li>Measure accurately.</li> </ul>
9. Open, course, holey texture.	<ul style="list-style-type: none"> <li>Salt omitted.</li> <li>Too much yeast.</li> <li>Too much liquid.</li> </ul>	<ul style="list-style-type: none"> <li>Assemble ingredients as listed in recipe.</li> <li>Measure right amount of recommended yeast.</li> <li>Reduce liquid by 15ml/3tsp.</li> </ul>
10. Centre of loaf is raw, not baked enough.	<ul style="list-style-type: none"> <li>Too much liquid.</li> <li>Power cut during operation.</li> <li>Quantities were too large and machine could not cope.</li> </ul>	<ul style="list-style-type: none"> <li>Reduce liquid by 15ml/3tsp.</li> <li>If power is cut during operation, for more than 8 minutes you will need to remove the unbaked loaf from the pan and start again with fresh ingredients.</li> <li>Reduce amounts to maximum quantities allowed.</li> </ul>
11. Bread doesn't slice well, very sticky.	<ul style="list-style-type: none"> <li>Sliced while too hot.</li> <li>Not using proper knife.</li> </ul>	<ul style="list-style-type: none"> <li>Allow bread to cool on rack at least 30 minutes to release steam, before slicing.</li> <li>Use a good bread knife.</li> </ul>
<b>CRUST COLOUR AND THICKNESS</b>		
12. Dark crust colour/ too thick.	<ul style="list-style-type: none"> <li>DARK crust setting used.</li> </ul>	<ul style="list-style-type: none"> <li>Use medium or light setting the next time.</li> </ul>
13. Loaf of bread is burnt.	<ul style="list-style-type: none"> <li>Bread maker malfunctioning.</li> </ul>	<ul style="list-style-type: none"> <li>Refer to "Service and customer care" section.</li> </ul>
14. Crust too light.	<ul style="list-style-type: none"> <li>Bread not baked long enough.</li> <li>No milk powder or fresh milk in recipe.</li> </ul>	<ul style="list-style-type: none"> <li>Extend baking time.</li> <li>Add 15ml/3tsp skimmed milk powder or replace 50% of water with milk to encourage browning.</li> </ul>

## troubleshooting guide *(continued)*

<b>PROBLEM</b>	<b>POSSIBLE CAUSE</b>	<b>SOLUTION</b>
<b>PAN PROBLEMS</b>		
15. Kneader cannot be removed.	<ul style="list-style-type: none"> <li>You must add water to bread pan and allow kneader to soak before it can be removed.</li> </ul>	<ul style="list-style-type: none"> <li>Follow cleaning instructions after use. You may need to twist kneader slightly after soaking to loosen.</li> </ul>
16. Bread sticks to pan/ difficult to shake out.	<ul style="list-style-type: none"> <li>Can happen over prolonged use.</li> </ul>	<ul style="list-style-type: none"> <li>Lightly wipe the inside of bread pan with vegetable oil.</li> <li>Refer to "Service and customer care" section.</li> </ul>
<b>MACHINE MECHANICS</b>		
17. Breadmaker not operating/Kneader not moving.	<ul style="list-style-type: none"> <li>Breadmaker not switched on</li> <li>Pan not correctly located.</li> <li>Delay timer selected.</li> </ul>	<ul style="list-style-type: none"> <li>Check on/off switch <b>(8)</b> is in the ON position.</li> <li>Check the pan is locked in place.</li> <li>Breadmaker will not start until the countdown reaches the program start time.</li> </ul>
18. Ingredients not mixed.	<ul style="list-style-type: none"> <li>Did not start bread maker.</li> <li>Forgot to put kneader in pan.</li> </ul>	<ul style="list-style-type: none"> <li>After programming control panel, press start button to turn bread maker on.</li> <li>Always make sure kneader is on shaft in bottom of pan before adding ingredients.</li> </ul>
19. Burning odour noted during operation.	<ul style="list-style-type: none"> <li>Ingredients spilled inside oven.</li> <li>Pan leaks.</li> <li>Exceeding capacity of bread pan.</li> </ul>	<ul style="list-style-type: none"> <li>Be careful not to spill ingredients when adding to pan. Ingredients can burn on heating unit and cause smoke.</li> <li>See "Service and Customer care" section.</li> <li>Do not use more ingredients than recommended in recipe and always measure ingredients accurately.</li> </ul>
20. Machine unplugged by mistake or power lost during use. How can I save the bread?.	<ul style="list-style-type: none"> <li>If machine is in knead cycle, discard ingredients and start again.</li> <li>If machine is in rise cycle, remove dough from bread pan, shape and place in greased 23 x 12.5cm/9 x 5 in. loaf tin, cover and allow to rise until doubled in size. Use bake only setting <b>11</b> or bake in pre-heated conventional oven at 200°C/400°F/Gas mark 6 for 30-35 minutes or until golden brown.</li> <li>If machine is in bake cycle, use the bake only setting <b>11</b> or bake in pre-heated conventional oven at 200°C/400°F/Gas mark 6 and remove top rack. Carefully remove pan from machine and place on bottom rack in oven. Bake until golden brown.</li> </ul>	
21. E:01 appears on display and machine cannot be turned on.	<ul style="list-style-type: none"> <li>Oven chamber too hot.</li> </ul>	<ul style="list-style-type: none"> <li>Unplug and allow to cool down for 30 minutes.</li> </ul>
22. H:HH & E:EE appears in display and machine does not operate.	<ul style="list-style-type: none"> <li>Bread machine is malfunctioning. Temperature sensor error</li> </ul>	<ul style="list-style-type: none"> <li>See "Service and Customer care" section.</li> </ul>



Head Office Address:  
Kenwood Limited, New Lane, Havant, Hampshire PO9 2NH, UK  
[www.kenwoodworld.com](http://www.kenwoodworld.com)  
Designed and engineered by Kenwood in the UK  
Made in China